

STM6000 Gateway Box



STM6000 Gateway Box

Model : PFXSTM6B00D (BLUE)

■ Electrical Specifications

Rated Input Voltage		24 Vdc
Input Voltage Limits		19.2...28.8 Vdc
Voltage Drop		5 ms or less
Power Consumption	Max	6.8 W
	When power is not supplied to external devices	3.5 W
In-rush current		30 A or less
Noise immunity		Noise voltage: 1,000 Vp-p Pulse duration: 1 μ s Rise time: 1 ns (via noise simulator)
Voltage Endurance		1,000 Vac for 1 minute (between power terminal and FG terminal)
Insulation Resistance		500 Vdc, 10 M Ω or more (between power terminal and FG terminals)

■ Environmental Specification

Ambient air temperature	0 to 60 °C (32 to 140 °F)
Storage Temperature	-20 to 60 °C (-4 to 140 °F)
Ambient air and storage humidity	10%...90% RH (Non condensing, wet bulb temperature 39 °C [102.2 °F] or less)
Dust	0.1 mg/m ³ (10-7 oz/ft ³) or less (non-conductive levels)
Pollution Degree	For use in Pollution Degree 2 environment
Corrosive Gases	Free of corrosive gases
Air pressure (altitude range)	800 to 1,114 hPa (2,000 m [6,561 ft.] above sea level or less)
Vibration Resistance	IEC/EN 61131-2 compliant 5 to 9 Hz single amplitude 3.5 mm [0.14 in.] 9 to 150 Hz fixed acceleration: 9.8 m/s ² X, Y, Z directions for 10 cycles (approx. 100 min.)
Shock Resistance	IEC/EN 61131-2 compliant 147 m/s ² , X, Y, Z directions for 3 times
Electrical fast transient/burst	IEC 61000-4-4 2 kV: Power port (display unit) 1 kV: Signal ports
Electrostatic Discharge Immunity	Contact Discharge Method: 6 kV Air Discharge Method: 8 kV (IEC/EN61000-4-2 Level 3)

■ Interface Specification

Serial (COM1)	Asynchronous Transmission: RS-232C/422/485, Data Length: 7 or 8 bits, Stop Bit: 1 or 2 bits, Parity: None, Even or Odd, Data Transmission Speed: 2,400 to 115,200 bps, Connector: D-Sub 9 (plug)
USB (Type A)	Conforms to USB 2.0 (Type A) x 1 Power supply voltage: 5 Vdc \pm 5 % Output Current: 500 mA/port Maximum transmission distance : 5 m [16.4 ft.]
USB (micro-B)	Conforms to USB 2.0 (micro-B) x 1, Maximum transmission distance : 5 m [16.4 ft.]
Ethernet	IEEE802.3i/IEEE802.3u, 10BASE-T/100BASE-TX, Connector: Modular jack (RJ-45) x 2
Extension Display module	Connector RJ45 on the Din Rail adapter



SCIGATE AUTOMATION (S) PTE LTD

No.1 Bukit Batok Street 22 #01-01 Singapore 659592
Tel: (65) 6561 0488 Fax: (65) 6562 0588
Email: sales@scigate.com.sg Web: www.scigate.com.sg

Business Hours: Monday - Friday 8.30am - 6.15pm

Internal

■ Structural Specification

Grounding	Functional grounding: Grounding resistance of 100 Ω or less, 2 mm ² (AWG 14) or thicker wire, or your country's applicable standard (SG and FG are connected inside the product).
Cooling method	Natural air circulation
Structure	IP20
External dimensions (W x H x D)	145.6 x 108.23 x 41.4 mm (5.73 x 4.26 x 1.63 in) (excluding protrusions)
Weight	0.27 kg (0.6 lb) or less
Mounting	Din-Rail adapter included

NOTE:

EQUIPMENT DAMAGE

- Store this product in areas where temperatures are within the product's specifications.
- Do not restrict or block the product's ventilation slots.

Failure to follow these instructions can result in equipment damage.

■ Memory (Editor : BLUE)

Model No.		PFXSTM6B00D
Application Memory	Editor : BLUE	FLASH EPROM
		128MB
	Local Storage	FLASH EPROM 467MB
	Removable system	-
Backup Memory	Editor : BLUE	NVRAM 500KB
	Battery	Unreplaceable battery by the customer/ Primary battery for clock data backup

■ Memory (Editor : GP-Pro EX)

Model No.		PFXSTM6B00DE	
Application memory	Editor : GP-Pro EX	Media	FLASH EPROM
		Screen area*1	64 MB
		User font area	8 MB
		Logic program area	132KB (Equivalent to 15,000 steps)
		Free space	-
		Removable system	No
	Backup memory	Editor : GP-Pro EX	Screen area
Variable area			SRAM 64 KB
Battery		Unreplaceable battery by the customer/ Primary battery for clock data backup	

*1 Use the screen area when the user font area's capacity is exceeded – for example, when an image font or a picture font is used –.

STM6000 Gateway Box

Parts Identification

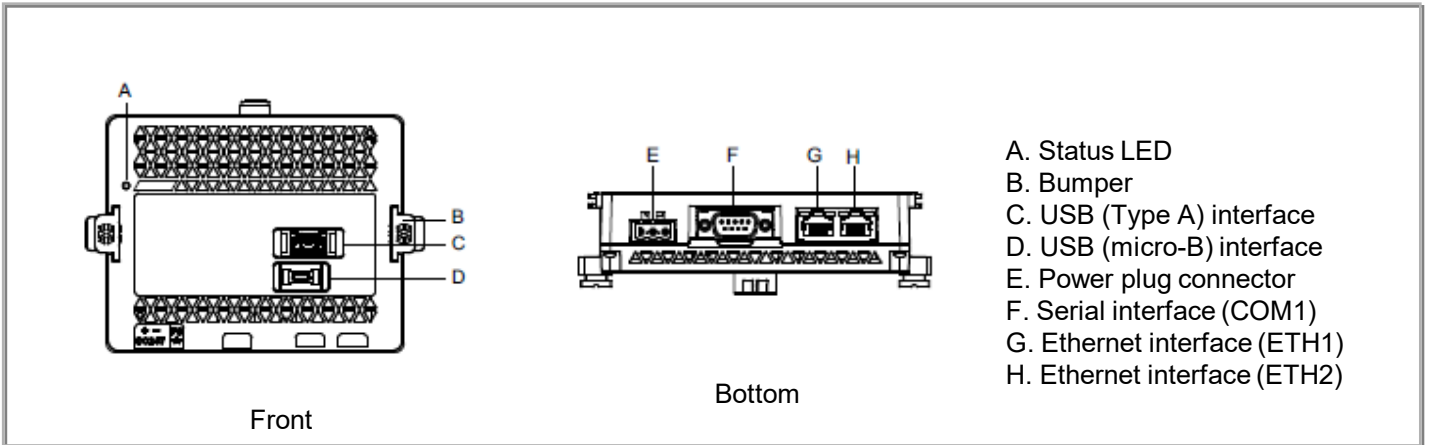

Dimensions

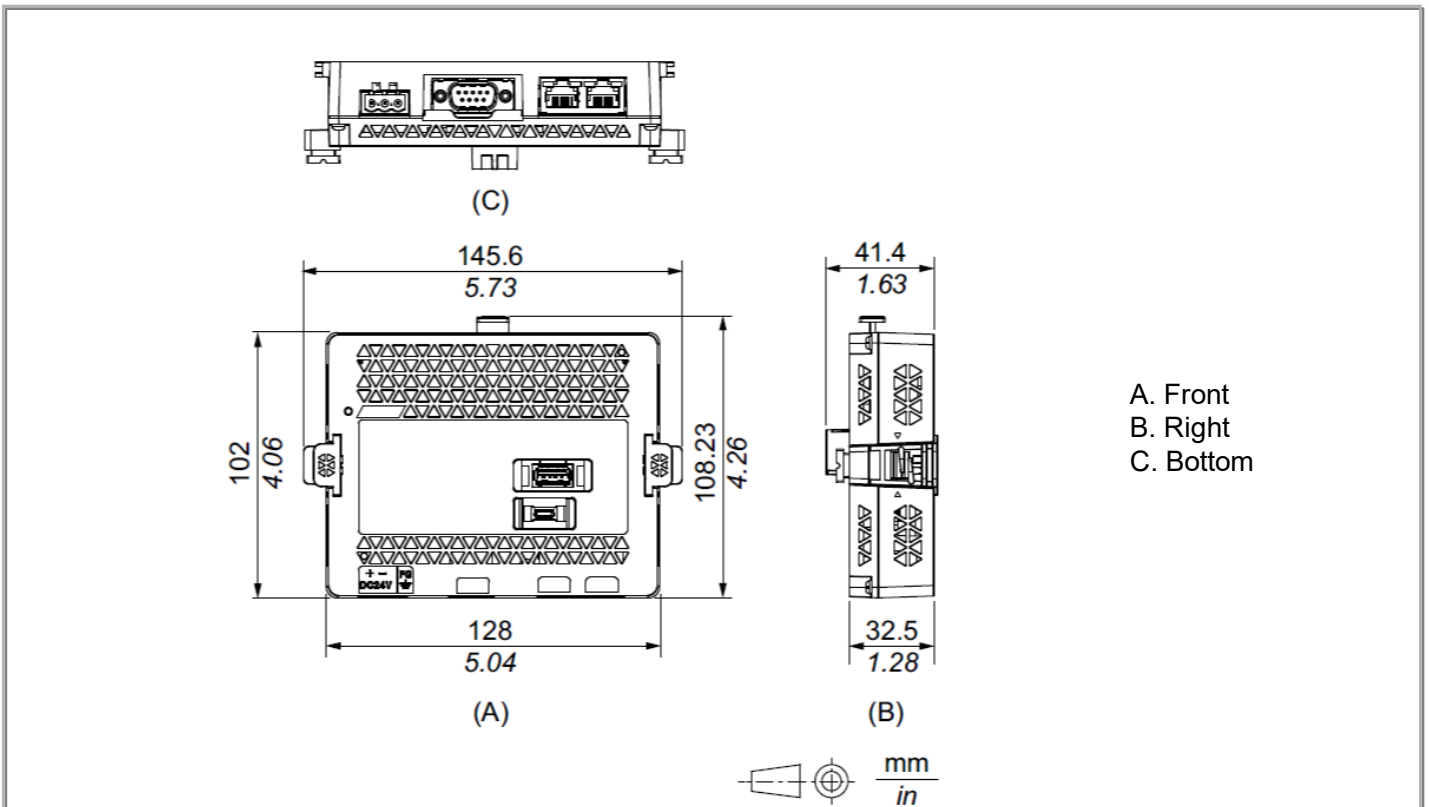

When Installation Adapter Attached

